

Lightening the Load: *Exploring Automotive Aluminum's Advantage Over Other Materials*



An Aluminum Association Webinar
www.aluminumintransportation.org

Defining Who We Are

The Aluminum Association's Aluminum Transportation Group (ATG)

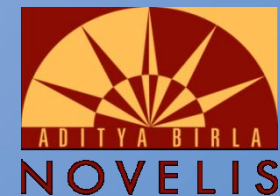

Why We are Here Today

- Promote a holistic, multi-material approach combining strong lightweight materials like aluminum with smart design and advanced powertrains
- Agenda
 - Introductions
 - Benefits of Lightweighting with Aluminum
 - New Third-Party Research
 - Strength and Stiffness Relevance for Typical Car Body Components
 - Multi-Material Comparative Lifecycle Assessment
 - Q & A

Introductions



Randall Scheps
ATG Chairman
Director – Ground
Transportation
Alcoa



Dr. Dietrich Wieser
EAA Technical Coordinator
Director – Business
Development, Ground
Transportation
Alcoa Europe



Pat McNulty
ATG Executive Committee
Automotive Market Director
Novelis

Aluminum Builds a Better Vehicle

**Mass
Reduction**



**Better Fuel
Economy**



**Infinitely
Recyclable**

**Reduced
Emissions**



**Enhanced
Performance**



**Improved
Safety**

Strength and Stiffness Relevance for Typical Car Body Components



Dr. Dietrich Wieser
EAA Technical Committee
Director – Business
Development, Ground
Transportation
Alcoa Europe

Lightweight Potential of Aluminum vs. High-Strength Steel

- Study conducted by the ika at the University of Aachen in Germany for the European Aluminum Association (EAA)
- Objective
 - Determine maximum weightsaving potential of steel vs. aluminum in automotive applications using a quantitative numerical analysis of a current model baseline vehicle

Qualitative Data Needs Refinement

General Perceptions Based on Qualitative Data

	Strength	Stiffness	Energy Absorption
Floor Structure	++	++	-
Crush Zone	+	++	++
Doors	++	+	++
Supports	++	++	-

Demand for Quantitative Analysis

- Methodology
 - Modeled car body to identify which body components are strength-limited or stiffness-limited
 - Translated the data for stiffness and strength relevance into the optimal lightweighting potential for each component, including
 - High-strength aluminum alloys
 - High-strength steel grades (including ultra high-strength steel)
 - Compared the maximum weight saving potential with aluminum and high-strength steel for all investigated BIW components of the reference vehicle

26 Components for Quantitative Evaluation

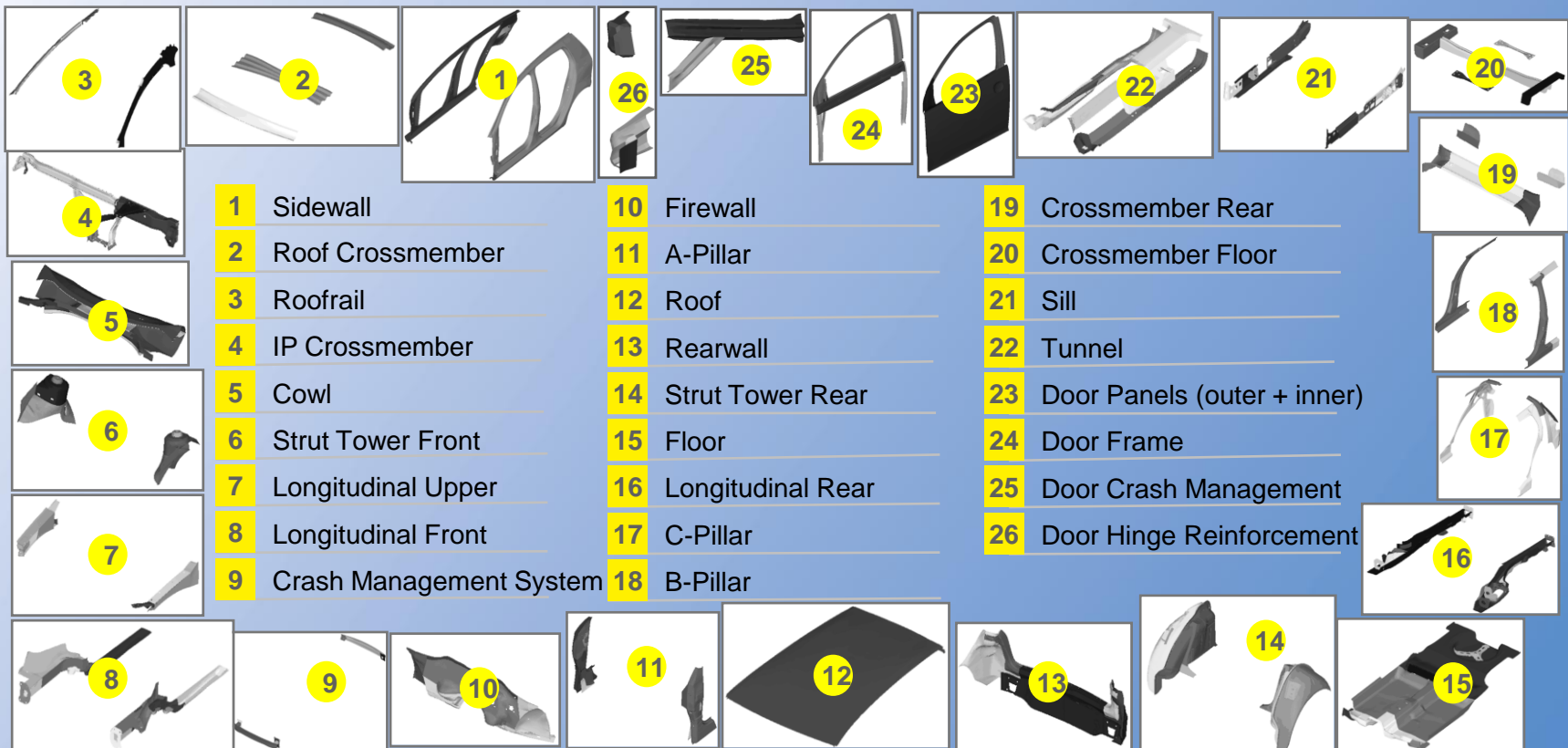

Stiffness Load Cases

Static Torsional Stiffness

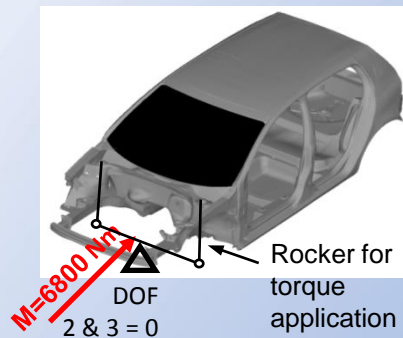

Evaluation:
Torsional stiffness calculated from deflection of evaluation point on front longitudinal

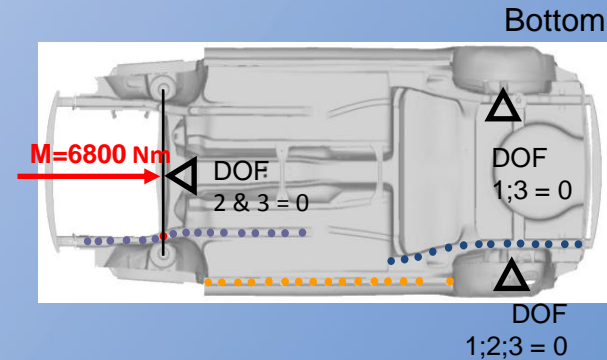

Static Bending Stiffness

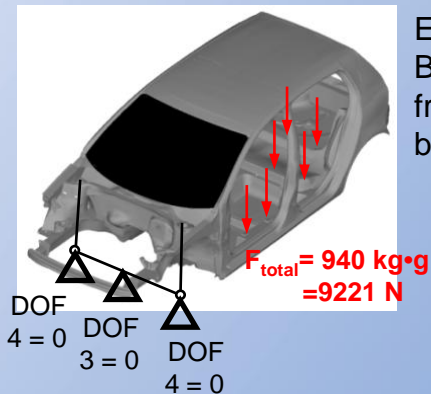

Evaluation:
Bending stiffness calculated from maximum deflection of bending lines (generally sill)

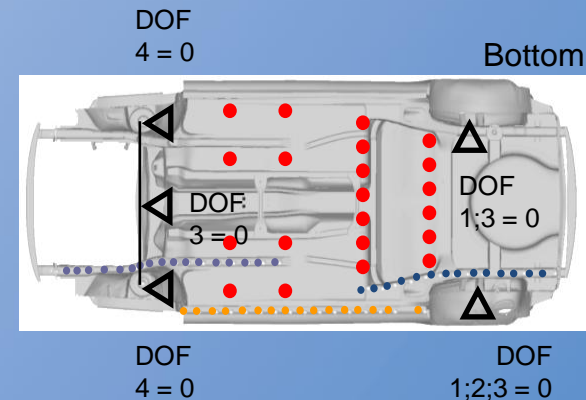

Red dots = Load/force application
Black dots = Deflection measured
Orange dots = Deflection measured
Blue dots = Deflection measured

Strength Load Cases

Evaluated Using European and U.S. Crash Standards

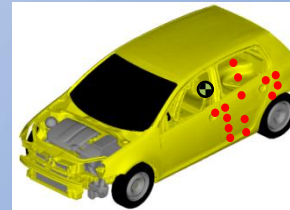
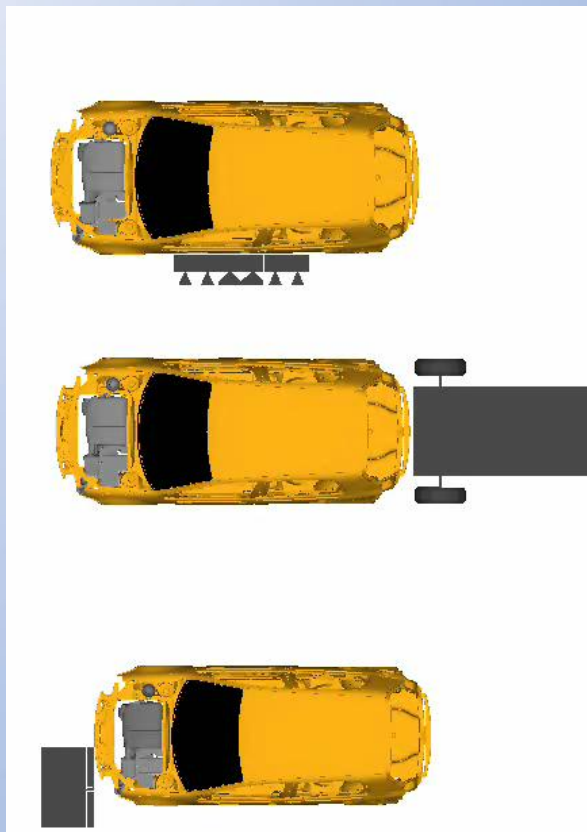

Euro NCAP Side Crash

- Velocity 50 km/h
- EEVC moving deformable barrier



FMVSS 301 Rear Crash

- Velocity 48 km/h
- Rigid moving barrier
- 0% offset

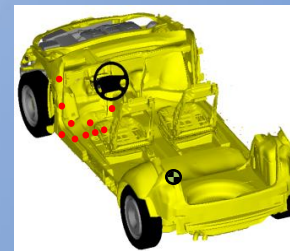

Euro NCAP Front Crash

- Velocity 64 km/h
- EEVC deformable barrier
- 40% offset

● Intrusion Evaluation Point ● Acceleration Evaluation Point

Results Strength vs. Stiffness

Strength and Stiffness Relevance Normalized to Values from 0 to 1

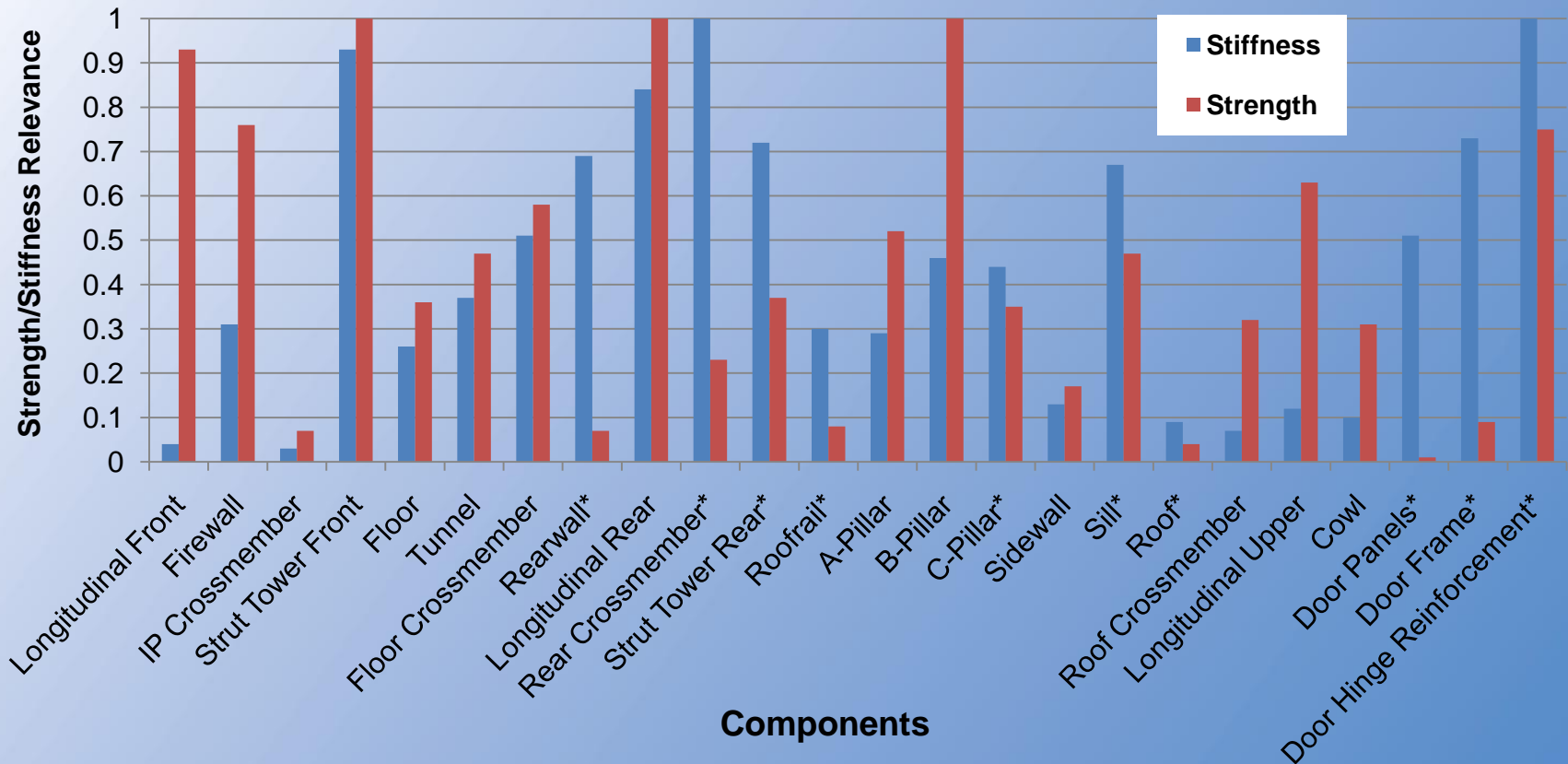

* Stiffness relevant components

Assessment of Lightweight Potential for Steel and Aluminum

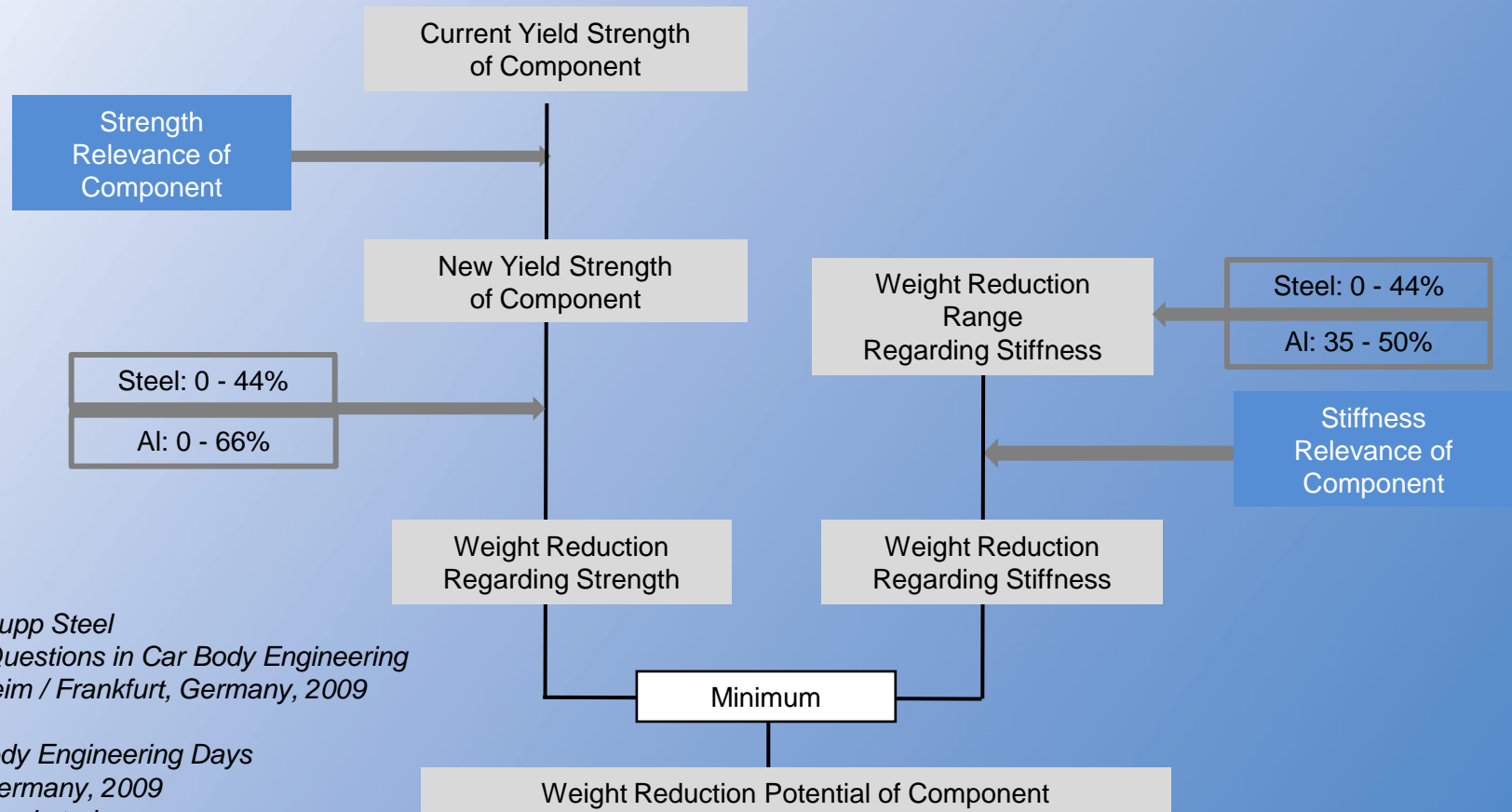

Literature:

- ThyssenKrupp Steel
Strategic Questions in Car Body Engineering
Bad Nauheim / Frankfurt, Germany, 2009
- Novelis
Aachen Body Engineering Days
Aachen, Germany, 2009
- Hydro internal study

Aluminum's Lightweighting Advantages Are Clear

Total maximum weight reduction compared to reference car:

Steel (with YS up to 1,200 MPa): **11%** **Aluminum** (with YS up to 400 MPa): **40%**

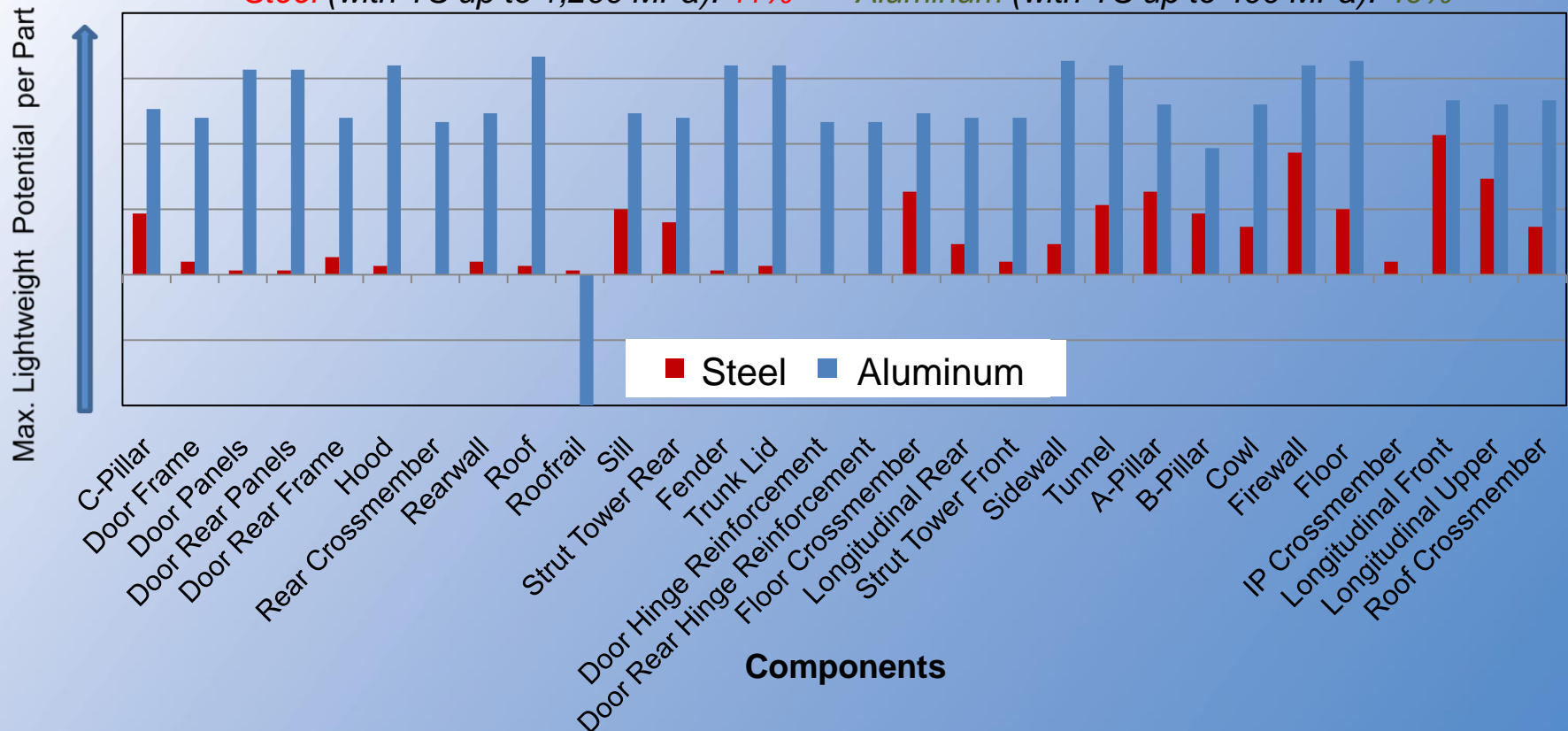

Key Takeaways

- The remaining **weight reduction potential** when designing the reference car body and closures
 - **High-strength steel** (with YS up to 1,200 MPa) = ~**11%**
 - **Aluminum** (with YS up to 400 MPa) = ~**40%**
- In addition to components where aluminum is already an established material, the longitudinal beam, roof, strut tower, floor and sidewall were identified as interesting components for future aluminum applications in multi-material BIW
- For most of the components strength is still not the limiting factor for substituting aluminum for steel
- To download the full study, visit the EAA website at:
<http://www.eaa.net/en/applications/automotive/studies/>

Multi-Material Comparative Lifecycle Assessment



Pat McNulty
ATG Executive Committee
Automotive Market Director
Novelis

Comparative Lifecycle Assessment Examines Key Materials

- Lifecycle analysis (LCA) study conducted by the Magnesium Front End Research and Development
 - Sponsorship of Canada, China and U.S.
 - Compares the environmental performance of the current steel design for the front end parts of a 2007 Cadillac CTS with new magnesium and aluminum designs
- The environmental aspects that are considered
 - Total primary energy
 - Greenhouse gases emissions (CO_2 , CH_4 , N_2O and perfluorocarbons)
 - Criteria air pollutants (particulates, NO_x , CO , non-methane volatile organic compounds, SO_x)

Aluminum is Clear Environmental Winner

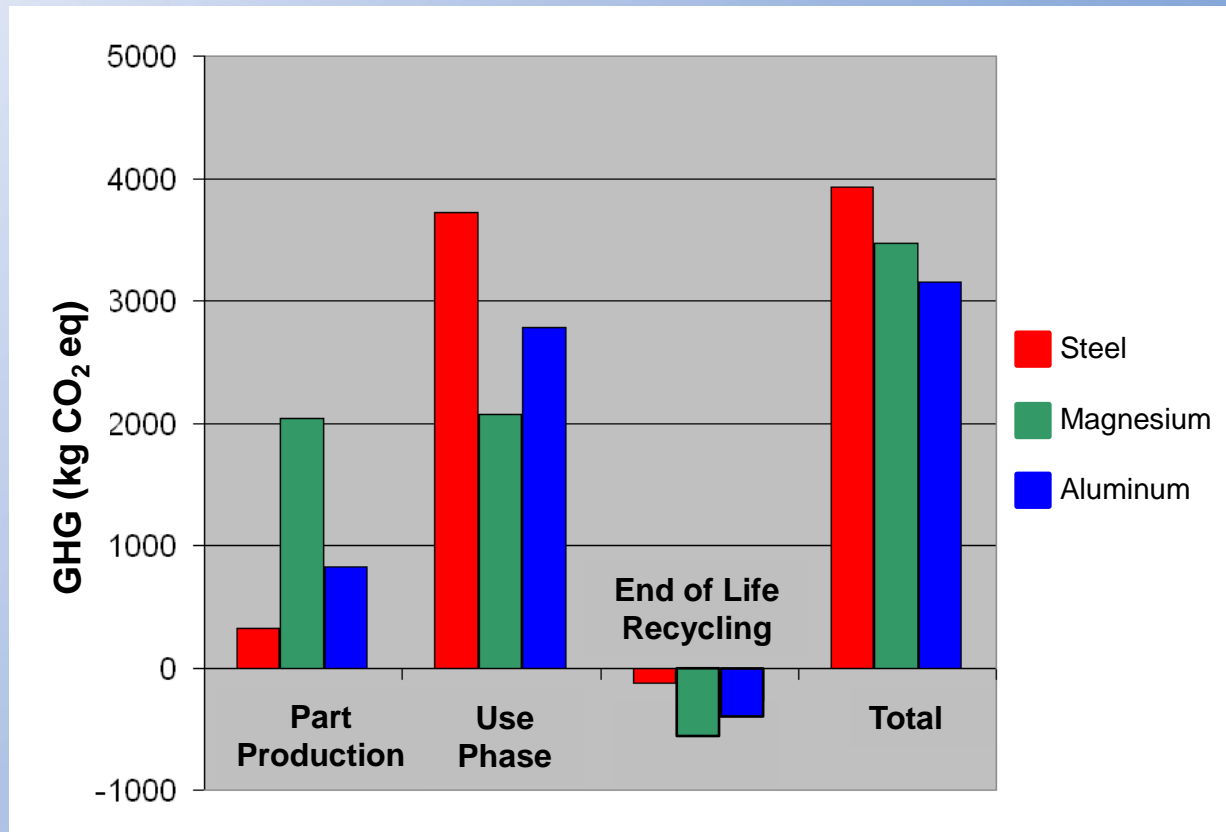

Aluminum Produces Less Emissions and Uses Less Energy Over Vehicle Lifetime

Lifetime Emissions Output

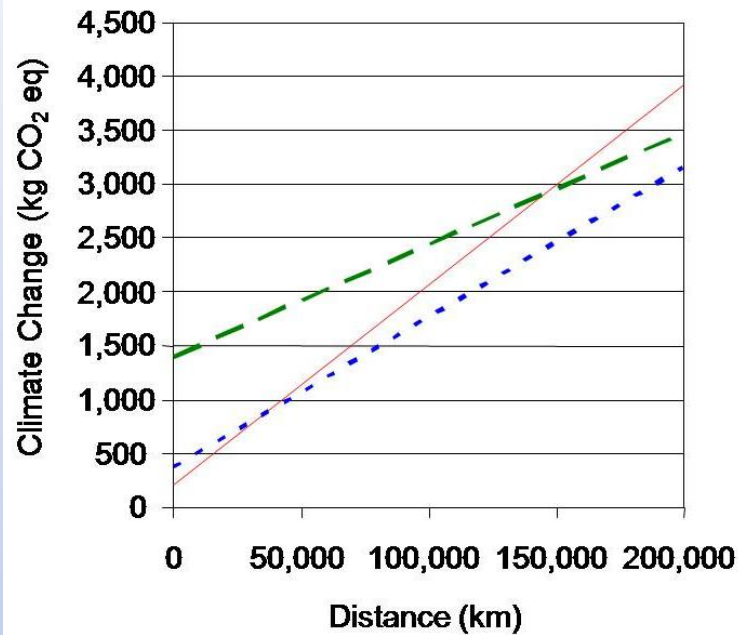

Lifetime Energy Output

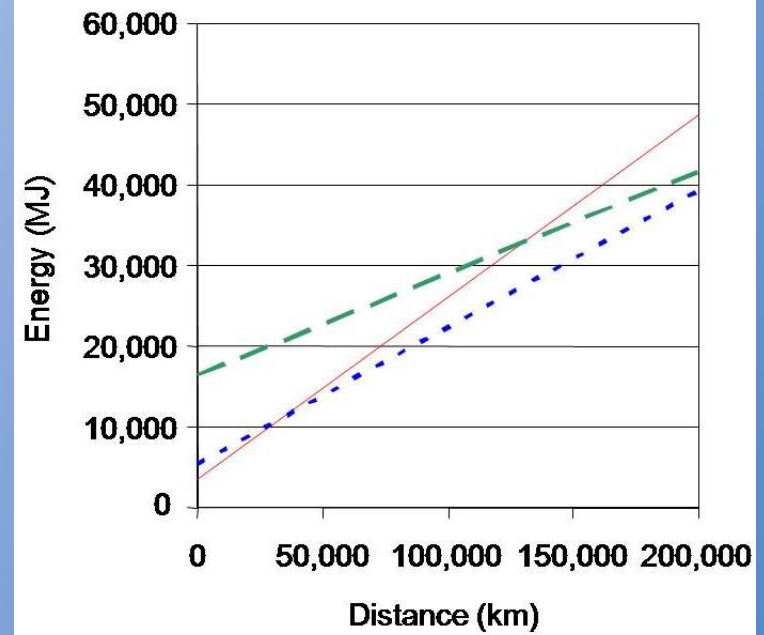

Key Takeaways

- When analyzing the full lifecycle of the metals, magnesium delivers a 15% energy savings compared with steel design and aluminum yields a 20% energy savings
- When looking at the total life cycle CO₂ emissions, magnesium is 12% better than steel and aluminum is 20% better
- The aluminum design achieved the best lifetime performance for overall energy use and greenhouse gas emissions
- To purchase a full copy of the study, visit the World Congress Technical Papers Store on the SAE website at: www.sae.org

Online Resources For You

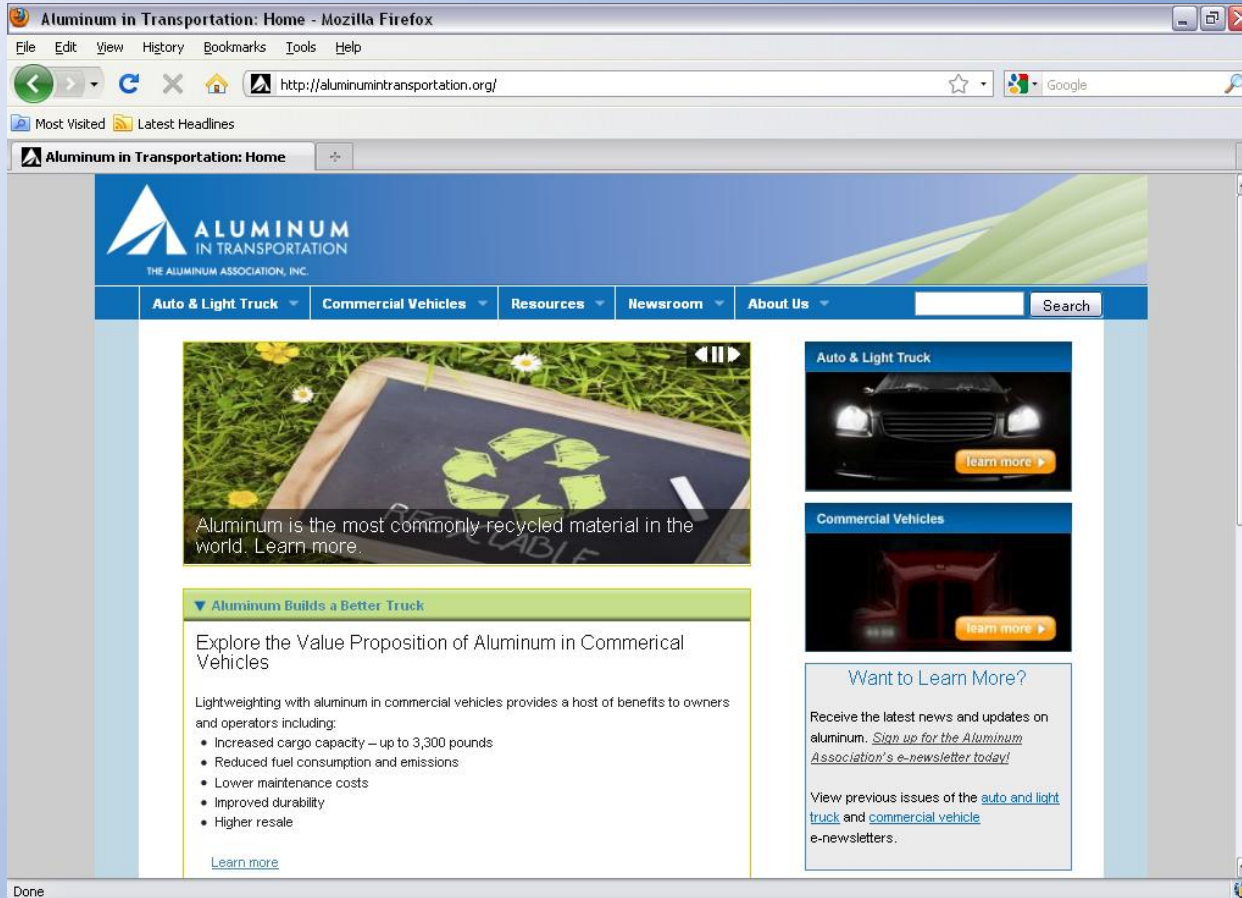

The screenshot shows a Mozilla Firefox browser window displaying the Aluminum in Transportation website. The browser's address bar shows the URL <http://aluminumtransportation.org/>. The website's header features the organization's logo and a navigation menu with categories: Auto & Light Truck, Commercial Vehicles, Resources, Newsroom, and About Us. A search bar is also present. The main content area includes a large image of a recycling symbol on a sign with the text "ALUMINUM IS THE MOST COMMONLY RECYCLED MATERIAL IN THE WORLD. Learn more." Below this is a section titled "Aluminum Builds a Better Truck" with the sub-heading "Explore the Value Proposition of Aluminum in Commercial Vehicles". This section lists benefits of aluminum in commercial vehicles, such as increased cargo capacity, reduced fuel consumption, lower maintenance costs, improved durability, and higher resale value. To the right, there are two smaller featured images: one for "Auto & Light Truck" and another for "Commercial Vehicles", each with a "Learn more" button. At the bottom right, a "Want to Learn More?" section invites visitors to sign up for the organization's e-newsletter and view previous issues.

Aluminum in Transportation: Home - Mozilla Firefox

File Edit View History Bookmarks Tools Help

<http://aluminumtransportation.org/> Google

Most Visited Latest Headlines

Aluminum in Transportation: Home

**ALUMINUM
IN TRANSPORTATION**
THE ALUMINUM ASSOCIATION, INC.

Auto & Light Truck Commercial Vehicles Resources Newsroom About Us Search

Aluminum is the most commonly recycled material in the world. [Learn more.](#)

Aluminum Builds a Better Truck

Explore the Value Proposition of Aluminum in Commercial Vehicles

Lightweighting with aluminum in commercial vehicles provides a host of benefits to owners and operators including:

- Increased cargo capacity – up to 3,300 pounds
- Reduced fuel consumption and emissions
- Lower maintenance costs
- Improved durability
- Higher resale

[Learn more](#)

Auto & Light Truck

[Learn more](#)

Commercial Vehicles

[Learn more](#)

Want to Learn More?

Receive the latest news and updates on aluminum. [Sign up for the Aluminum Association's e-newsletter today!](#)

View previous issues of the [auto and light truck](#) and [commercial vehicle](#) e-newsletters.

Question & Answer

Please submit questions through the box that appears on your screen



Contact Us

*For more information or to
download this presentation*

Visit www.aluminumtransportation.org

or

E-mail atginfo@aluminum.org